

Intelligent electronic knotting machine

**XFQ-01B**

**Repair Manual**

Version 1.0

Table of contents

Preface..... - 2 - 1. Advanced

Operations..... 1.1 Storage Switch Setting - 3 -

    Mode..... - 4 - 1.1.1 Storage Switch

        Overview..... - 4 - 1.1.2 Storage Switch

        Setting..... - 7 - 1.1.3 Automatic Processing

        Setting..... - 7 -

    1.2 Data Initialization..... - 8 - 1.2.1 Initialization

        Method and Content Description..... - 8 - 1.2.2 Initialization

        Method..... - 8 - 1.3 Software Version

Display..... - 9 - 1.4 Parallel

Movement..... - 10 - 1.5 Origin Position

Adjustment..... - 11 - 1.5.1 X/Y/Z Origin Position

    Adjustment..... - 11 - 1.5.2 Wire Clamp Position

    Adjustment..... - 12 - 1.5.3 Upper Needle Stop Position

    Adjustment..... 1.6 Input - 13 -

Detection..... - 15 - 2.

Maintenance..... - 16 - 2.1 Controller External

    and Internal Schematic Diagram..... - 16 - 2.1.1 Schematic Diagram of

        External Control Interface (Front Panel) ..... 2.1.2 Controller Opening - 16 -

        Direction..... 2.1.3 Schematic Diagram of Controller - 17 -

        Internal Interface Locations and Directions..... - 17 - 2.2 Explanation of Alarm Information

    and Repair Methods for Various Parts..... - 19 - 2.2.1 Power On/Off

        Faults..... - 19 - 2.2.2 Spindle Motor

        Faults..... - 19 - 2.2.3 Fabric Feeding

        Faults..... 2.2.4 Presser Foot - 20 -

        Faults..... - 21 - 2.2.5 Data Editing

        Faults..... - 21 - 2.2.6 Device

        Faults..... - 21 - 2.2.7 Other

        Faults..... - 22 - 2.3 No alarm abnormal

    conditions..... - 22 - 2.3.1 Power switch

        malfunction..... - 22 - 2.3.2 Electromagnet

        malfunction..... - 22 - 2.3.3 Keyboard

        malfunction..... - 22 - 2.3.4 Machine in abnormal state after

        startup..... - 23 - 2.3.5 Presser foot frame has unnecessary movement

        after sewing..... - 23 -

## Foreword

To fully utilize the superior performance of this product and ensure the safety of maintenance personnel and equipment

Please read this instruction manual carefully before using it.

The repair manual is a limited-quantity attachment; please keep it safe after use for future reference.

It is used for subsequent equipment inspection and maintenance.

If you have any questions or special requirements regarding the maintenance of this knotting machine, please feel free to contact us.

Contact the company's after-sales service center.

The contents of this instruction manual are subject to change without notice.



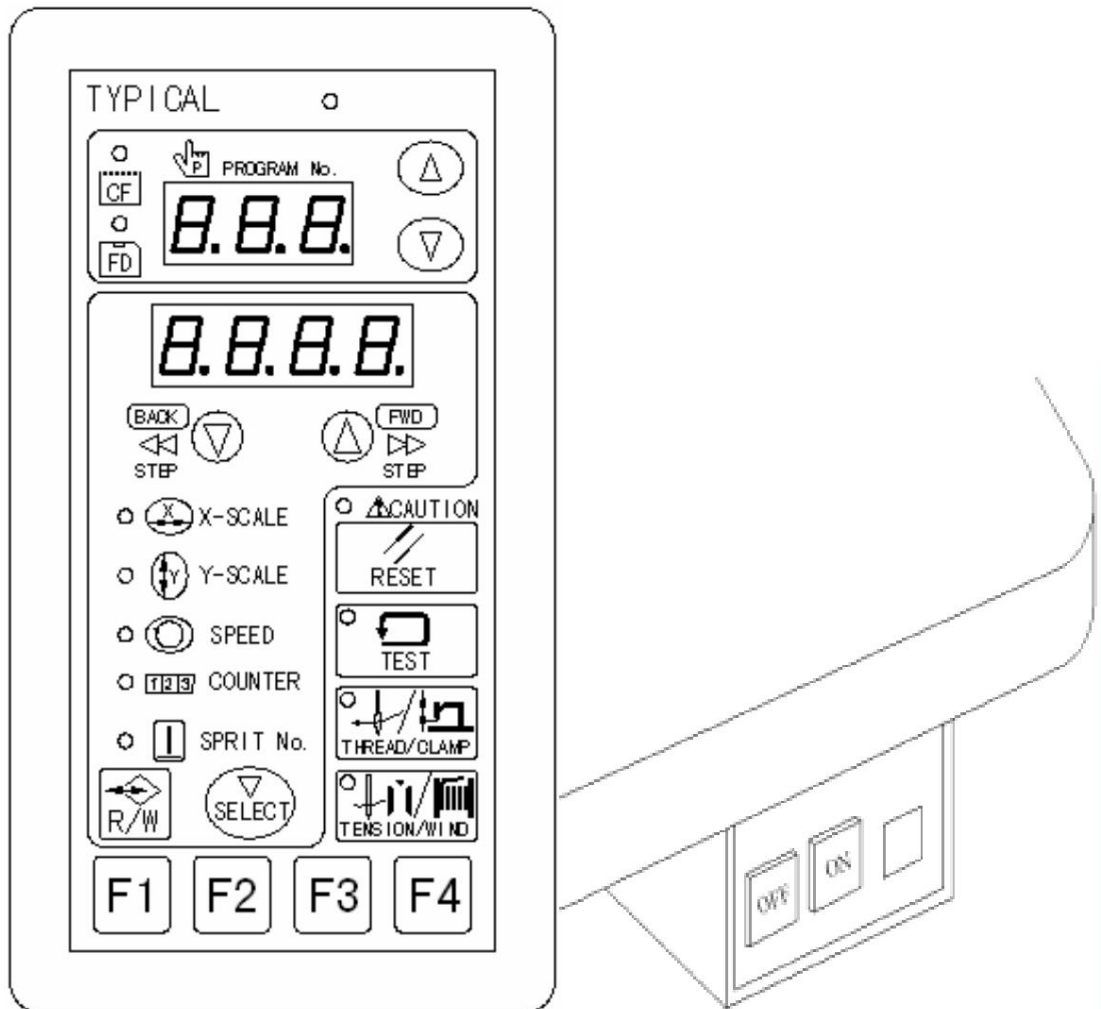

## 1. Advanced Operations



A list of

power switch

advanced keyboard operations:

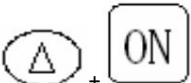
<p>1. Storage switch setting mode</p> 	<p>4. Parallel Movement Mode</p> 
<p>2. Data initialization function</p> 	<p>5. Origin Position Adjustment Mode</p> 
<p>3. Software version display</p> 	<p>6 Input Detection</p> 

## 1.1 Storage Switch Setting Mode

### 1.1.1 List of Storage Switches

Sequence number	number setting	content	initial value
001		value Presser foot rise sequence after sewing is completed	OFF
	OFF	rises at the final position of the needle.	
	ON	moves up after moving to the sewing start point.	
002		Number of loop steps	OFF
	OFF	Maximum 15 steps.	
	ON	Maximum 80 steps.	
003		2-speed presser foot	OFF
	OFF	is invalid.	
	ON	Press the pedal to 1st gear and stop in the middle position; press down to 2nd gear.	
050 (Reserved)	051		1
(Reserved)	Startup		OFF
100		Speed Control	OFF
	OFF	The sewing speed for the first 1-5 stitches is set according to the memory switch 151~ Start at the set speed of number 155.	
	ON	Sewing begins at the set speed (400 rpm, 400 rpm, ...). Start at 600 rpm or 800 rpm, and start slowly.	
150		Spindle reverses and rises	OFF
	OFF	is invalid.	
	ON	indicates that the motor reverses when the spindle stops.	
151		Start sewing with the first stitch at a speed	400
		of 400.	
152		Start sewing the second stitch at a speed	800
		of 800.	
153		Start sewing the third stitch at a speed of	1800
		1800.	
154		Start sewing the fourth stitch at a speed of...	2700
		2700	
155		Sewing begins, 5th stitch speed	3200
		3200	
156		stitches, speed before finishing sewing (5 stitches).	3200
		3200	
157		Sewing finished 4, needle speed	3200
		3200;	
158		Sewing finished 3, needle speed...	1800
		1800	
159		Sewing finished 2 needle speed	400

	400		
161 (Retained)	162		OFF
(Retained)	Limit		OFF
163	400	maximum sewing speed	3200
	3200	For the current sewing speed, the sewing speed of the user program and the loop program. All degrees are effective.	
164 (Reserved)			OFF
165		Reverse rise angle	-60
		-60° to 0°. Adjustable between -60° and 0°. 1-needle test fabric	
200		feed.	OFF
	OFF	The trial fabric feeding begins when the foot pedal is pressed and automatically continues to the end. One injection.	
	ON	The test fabric feed proceeds stitch by stitch as the foot pedal is pressed.	
250 (Reserved)	251		OFF
(Reserved)	252		100
(Reserved)	253		OFF
(Reserved)	260		OFF
(Reserved)	261		0
(Reserved)	262		0
(Reserved)	263		0
(Reserved)	264		0
(Reserved)	265		0
(Reserved)	266		0
(Reserved)	267		0
(Reserved)	Production		0
300		Quantity Counter Display	OFF
	OFF	bottom line counter display	
	ON	Production Counter Display	
350 (Reserved)	351		0
(Reserved)	User Program		OFF
400		User program mode is invalid. (OFF)	OFF
	ON	User program mode is active.	
401		Loop program	OFF
	OFF	The OFF loop program mode is invalid. Use the user-	
	ON	programmed sewing method, sewing sequentially according to the pre-defined program steps. ý (rèn)	
402		Percentage display to millimeter display conversion	OFF
	OFF	percentage display is valid.	
	ON	millimeter display is active.	
403		Presser foot magnification setting range	ON
	OFF	sewing range is independent of the presser foot size.	
	ON	sewing area must be within the presser foot frame area.	

450 (Reserved)	451	OFF
(Reserved)	452	0
(Reserved)	Sewing	OFF
460	area restriction in the X direction, unit mm $\pm$ 40	40
	can be adjusted between 1 and 40.	
461	Y-direction sewing area limitation, unit mm $\pm$ 30.	30
	Adjustable between 1 and 30. 462 (Retained) 463	
(Retained)	464	OFF
(Retained)	465	OFF
(Retained)	466	OFF
(Retained)	Thread	OFF
clamping device		OFF
500	OFF. The wire clamp is ineffective.	OFF
	The ON clamping device is effective.	
550	Bottom line clamping device	ON
	OFF is invalid.	
ON uses a bottom clamp device.		
551	Setting the loose thread at the start of sewing	OFF
	The OFF loose wire function is disabled.	
The ON loose wire function is active.		
552 (Retained)	553	0
(Retained)	Number of	2
554	loose stitches	3
	1-5. Adjustable between 1 and 5 stitches. 655 (Retained)	
Automatic processing		OFF
750	mode.	OFF
	OFF is invalid.	
ON is valid.		
1000 and 3000. 751	Automatic processing interval time adjustment, unit:	2000
	1000 milliseconds, step size: 100, adjustable between 3000	
752 (Reserved)	Head	0
850	Unit Identifier Parameters	0
	0. Display the machine model based on the head unit identifier.	
	1. Thin material.	
	2 thick material.	
691 Button sewing machine.		

### 1.1.2 Storage Switch Setting



The PROGRAM No. display area shows the storage switch number, and the menu display area shows its set value. (See below.)

picture:

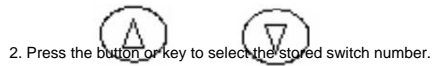
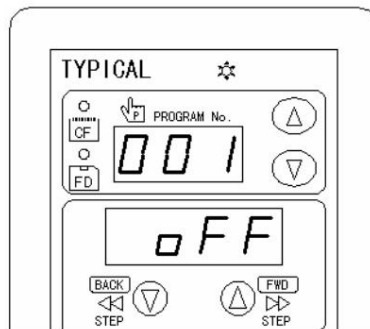

### 1.1.3 Automatic Processing Settings

1. Select memory switch 750 and change its setting to ON to activate the automatic processing function. For example...

The image below:

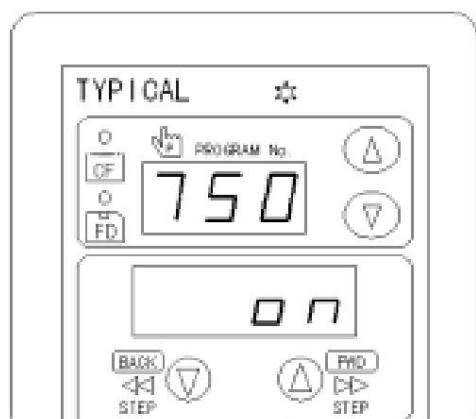



2. Select memory switch 751 and set the automatic processing interval to 3000ms (default is...).

2000ms, range: 1000~3000ms, step size 100ms). Once set, press...

Exit, now in a sewing-ready state.

3. Select the pattern to be automatically processed and set the sewing speed.

Press simultaneously   Press and hold the key for 2 seconds, then release. Press the foot switch to perform one...

The machine will automatically sew once after a 3000ms wait. Automatic processing has then begun.

4. To exit automatic processing, press the button after the machine has completed one sewing cycle.  Key, machine



The machine stops automatic processing and is ready for sewing.

## 1.2 Data Initialization

### 1.2.1 Initialization Method and Content Description

Initialization method	content	
001	SEW (Reserved)	
002	MEM	Restore memory switch parameters to factory settings; clear patterns 300-999. data.
003	ALL	Original pattern data and memory switch parameters are restored to factory settings; user Clear all programs, loop programs, and pattern data from 300 to 999.
004	USE	clears all user programs and loop programs.

### 1.2.2 Initialization Method



1. Press   At the same time, turn on the power switch.



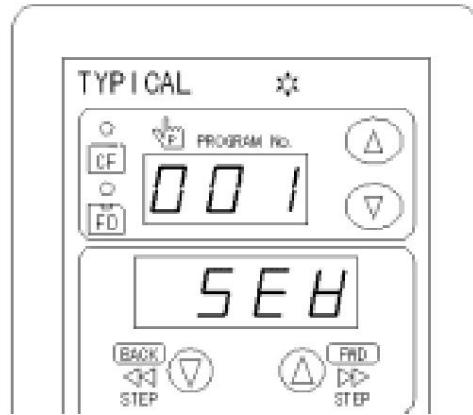

(The keyboard will first display the machine model. Once the initialization screen appears, release the key.) 

(Key.) As shown in the image below:

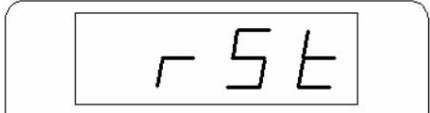

2. Press the  or key  to select the reset method.

3. Press  Key, menu display area  until it becomes apparent



Show  At this point, the buzzer sounds once, indicating that the initialization is complete.

4. Press  Exit, now in a sewing-ready state.

### 1.3 Software Version Display

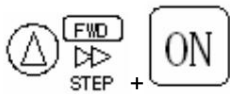
1. Press the button  while turning on the power switch. 



(The keyboard will first display the machine model; wait until the software version interface appears, then release the key.)  

(Key.) As shown in the image below:

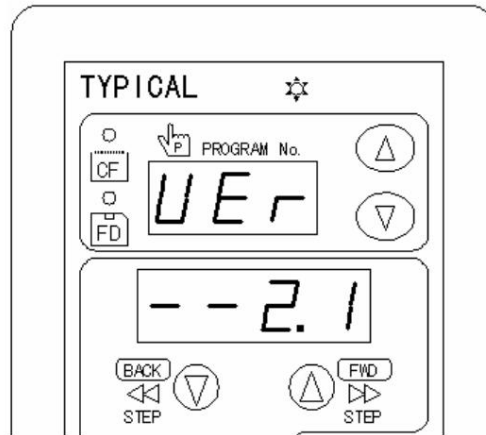

2. Press  Exit, now in a sewing-ready state.

### 1.4 Parallel Movement

1. Press   Press the key and the button simultaneously to turn on the power switch .



(The keyboard will first display the machine model. Wait until the interface for adjusting the origin position is displayed, then release the key.)

 Key and  (Key.) As shown in the image below:

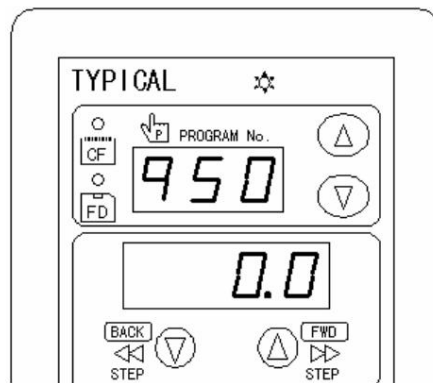

950 indicates the X direction, and 951 indicates the Y direction.

2. Press the button or key to select the direction number you want to move to.  

3. Press the key or the button to modify the value in the menu display area; the presser foot frame will move accordingly.  



The value moves according to the changes. Each time a key or button is pressed, the value increases or decreases.

0.1mm.



4. Once you have moved to the desired position, press [button/button]. Exit. First, locate the presser foot frame before adjustment.

Find the original position, and then find the new original position after parallel movement.

Note: After setting up the parallel movement, you must first confirm the sewing pattern before proceeding.

To begin work.

## 1.5 Origin Position Adjustment

### 1.5.1 Adjustment of X/Y/Z origin position

1. Press  Press the key and the button simultaneously to turn on the power switch. 



(The keyboard will first display the machine model. Wait until the interface for adjusting the origin position is displayed, then release the key.)



(Key.) As shown in the image below:

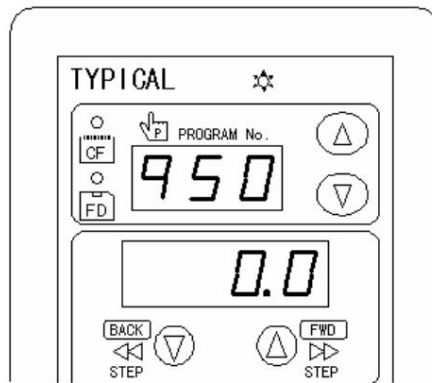

950 represents the X direction, 951 represents the Y direction, and 952 represents the Z direction.

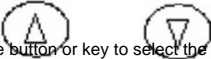
2. Press the button or key to select the number whose origin position needs to be adjusted. 

Press  Use the key or the button to modify the value in the menu display area; the presser foot frame will move accordingly.



The value moves according to the changes. Each time a key or button is pressed, the value increases or decreases.

0.1mm.

3. After adjusting to the appropriate position, first use a rod-like object to press the corresponding position inside the small hole on the motor's rear cover.



Press the key, then press the key and the key simultaneously to clear the operation keyboard menu display area.

The value is restored to the [0.0] display state.



Motor back cover



F1-F4 keys on the keyboard



4. Once adjustments are complete, press... Exit, now in a sewing-ready state.

Note: During step 3, if adjustments were made in two or three directions, the numerical value may be reset.

You can press all the buttons on the motor at once, and then clear the values on the control panel one by one.

### 1.5.2 Adjustment of the clamp position



1. Press the key and the button simultaneously to turn on the power switch.



(The keyboard will first display the machine model. Wait until the interface for adjusting the origin position is displayed, then release the key.)



(Key.) As shown in Figure 1:

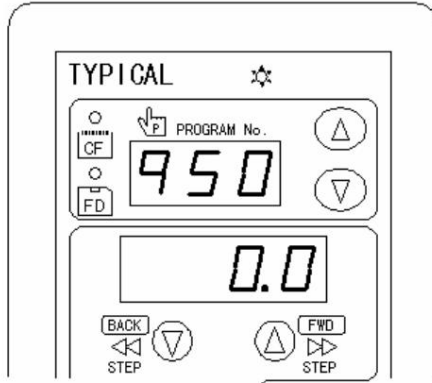

Figure 1

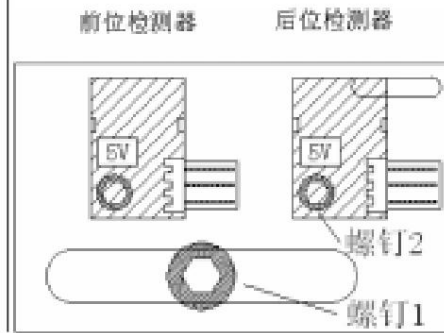





Figure 2

2. Press the  or button to select position 953 and adjust the number.
3. Pull the wire clamp connecting plate to move the wire clamp under the needle hole, so that the hole on the wire clamp is concentric with the needle hole.  
Adjust the position of the front position detector of the clamping wire (as shown in Figure 2 above) until the menu on the operation keyboard is displayed.  
When the displayed character changes between N-0 and N-1, tighten detector fixing screw 1.

4. Press  Each movement of the wire clamp is one cycle. Then, check the origin position of the wire clamp again.

Is it accurate? If not, repeat step 3.

5. Press the  or button to select position 954 and adjust the number.
6. Pull the wire clamp connecting plate to move the wire clamp to the retracted position. Adjust the wire clamp position and then position the detector.  
(As shown in Figure 2 above), wait until the menu display area of the operation keyboard displays the characters between H--0.  
When H changes between H and H1, tighten detector fixing screw 2.

7. Press  Each movement of the wire clamp occurs once. Then check the retracted position of the wire clamp again.

Is it accurate? If not, repeat step 6.

8. Press  Exit, now in a sewing-ready state.

### 1.5.3 Adjustment of the stop position of the upper needle

1. Open the rear cover of the spindle motor and loosen the screws securing the encoder disc. See Figure 1 below:

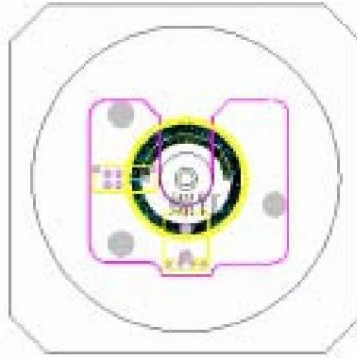

Figure 1

2. Press the  and  keys simultaneously to turn on the power switch. 



(The keyboard will first display the machine model. Wait until the interface for adjusting the origin position is displayed, then release the key.)

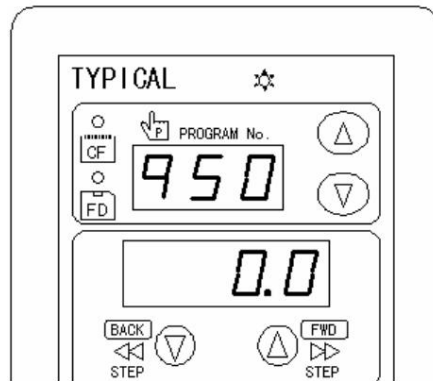
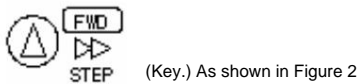





Figure 2

3. Press the  or  button to select position 955 and adjust the number.
4. Adjust the needle (DP17) to 17mm from the needle plate, rotate the code plate holder, and wait until the operation keyboard menu appears.

When the character displayed in the single display area changes between U--1 and U--0, tighten the code disk fixing screws.

5. Press  Each rotation of the spindle motor completes one movement. This is to check if the motor's origin position is accurate.

Confirmed. If inaccurate, repeat step 4.

6. Press  Exit, now in a sewing-ready state.

## 1.6 Input Detection

1. Press the button  while turning on the power switch.

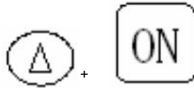

(The keyboard will first display the machine model. Once the input detection interface appears, release the key.) 

(Key.) As shown in Figure 1:

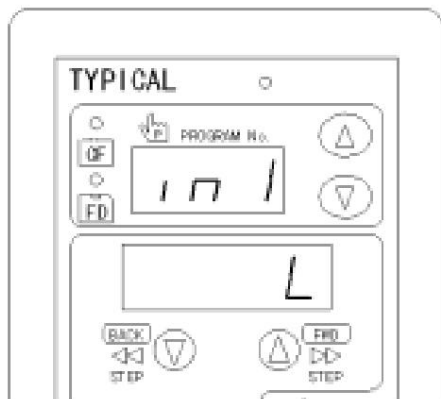

Figure 1

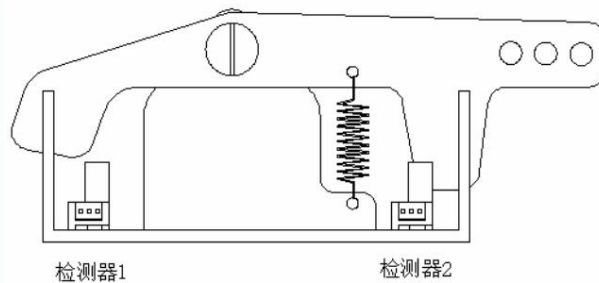



Figure 2

2. Press the key  or arrow key  to select input 1 and input 2.

The PROGRAMNo. display area shows [IN1], corresponding to detector 1.

The PROGRAMNo. display area shows [IN2], corresponding to detector 2.

3. When the PROGRAMNo. display area shows [IN1], test detector 1 by pressing the foot switch.

The single display area alternates between [L] and [H]. As shown in Figure 2, when the

PROGRAMNo. display area displays [IN2], test detector 2 is activated by pressing the foot switch.

The single display area alternates between [H] and [L]. (See Figure 2)

4. Turn off the power switch to exit the input detection state.

Note: If the displayed result is the same as the above result during actual operation, it indicates that the two foot switch functions are working correctly.

The detectors are all qualified, and the wiring is correct.

## 2. Repair

### 2.1 Schematic diagram of the controller's exterior and interior

#### 2.1.1 Schematic diagram of external control interface (front panel)

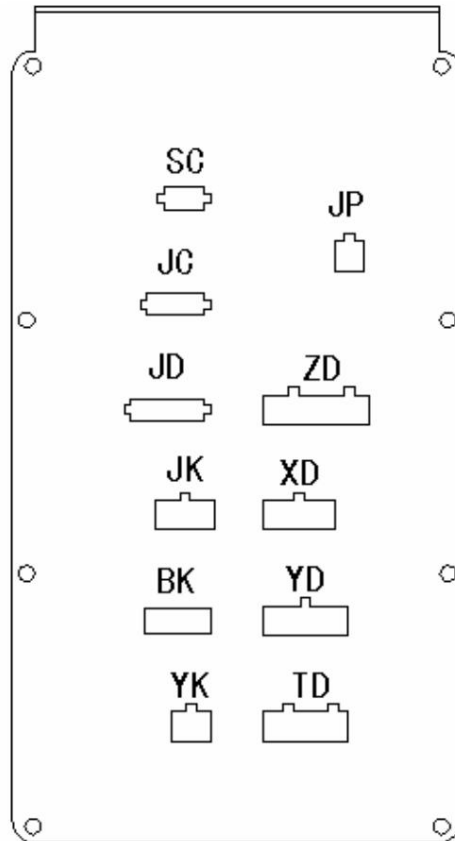

Character	description
SC	loose wire electromagnet
JC	Tangential Electromagnet
JD	Wire-Clamping Motor
JK	Wire Clamp Position Switch and Head Identifier
BK	head switch
YK	foot switch
JP	operation keyboard
ZD	spindle motor and encoder
XD	X-axis motor and encoder
YD	Y-axis motor and encoder
TD	presser foot motor and encoder

### 2.1.2 Open the controller direction

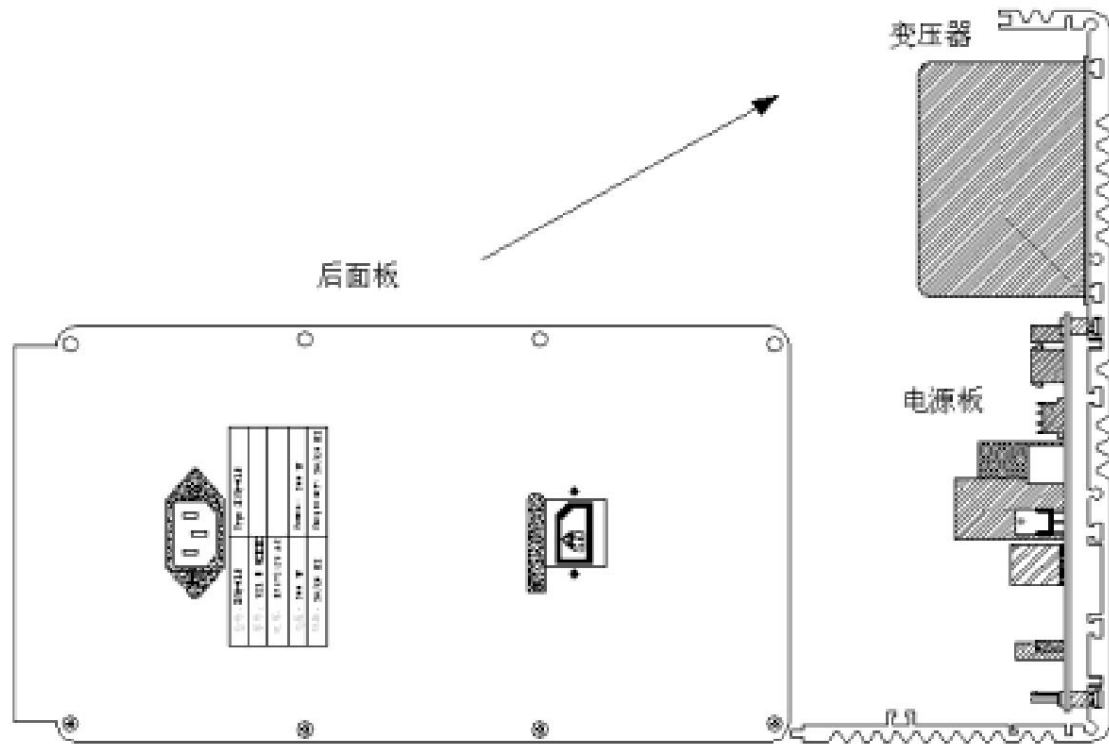

When opening the controller, be sure to open it in the direction shown in the diagram above; otherwise, it may...

It can easily damage the internal cables.

### 2.1.3 Schematic diagram of the location and destination of each interface inside the controller

1. Schematic diagram of the location of each interface inside the controller

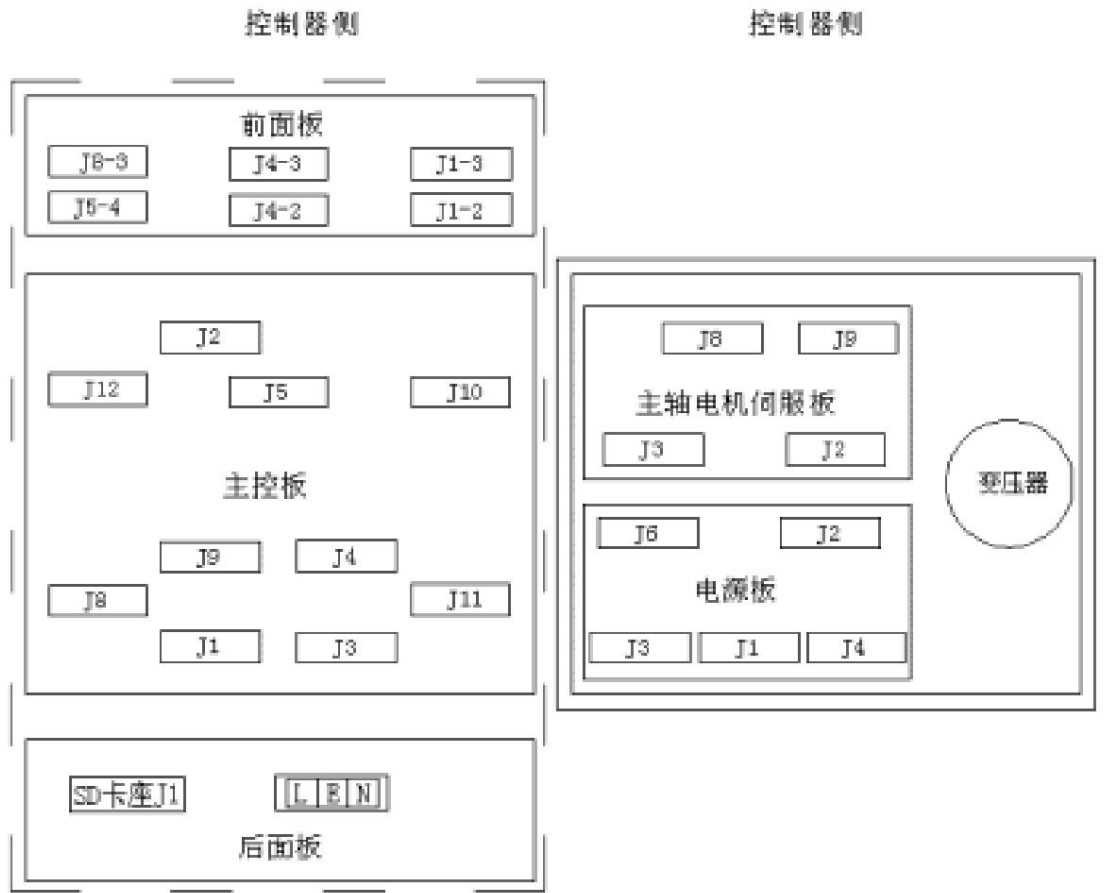

2. Description of the destinations of each interface within the controller

main control board

starting point	end
J1	Power board
J2	J6, Power board
J3	J4, Spindle motor servo board
J4	J3, Adapter board
J5	J8-3, Adapter board
J8	J1-3, Adapter board J5-4
J9	SD card slot J1
J10	adapter board J1-2
J11	adapter board J1-2
J12	adapter board J1-2

spindle motor servo board

starting point	end
J2	Adapter board J4-3,
J3	Main control board
J8	J3, Adapter board J4-2,
J9	Power supply board J3

power board

starting point	end
J1	Rear panel power socket

J2	transformer
J3	Spindle motor servo board J9, main
J4	control board J2,
J6	main control board J1

## Adapter board

starting point	end
J1-2	Main control board J10/J11/J12, main
J1-3	control board J5,
J4-2	spindle motor servo board J8,
J4-3	spindle motor servo board J2, main
J5-4	control board J8,
J8-3	main control board J4

## 2.2 Explanation of alarm information and maintenance methods for each part

## 2.2.1 Power-on/off faults

Alarm Code	Causes and solutions
E025	The power is turned on when the foot switch is pressed to position 2. Turn off the power and confirm that the foot switch is on.
E035	The power is turned on when the foot switch is pressed to position 1. Turn off the power and confirm that the foot switch is on.
E050	The machine head was detected to have tilted after the power was turned on. Turn off the power and stand the sewing machine head upright. Confirm the cable connection from the head switch to the front BK position. Confirm the cable connection status from the main control board J5 to the adapter board J1-3.
E055	The machine head tipped over during the power-on process. Turn off the power and stand the sewing machine head upright. Confirm the cable connection between the head switch and the front BK position. Confirm the cable connection status from the main control board J5 to the adapter board J1-3.

## 2.2.2 Spindle motor malfunctions

Alarm Code	Causes and solutions
E100	After the power is turned on, the spindle motor cannot find the origin/does not return to the origin. Turn off the power and turn the handwheel to check if the spindle is stuck. Confirm the cable connection from the spindle motor to the ZD position on the front panel. Confirm the cable connection status from the main control board J5 to the adapter board J1-3. Confirm the cable connection status from the main servo board J3 to the main control board J3. Confirm the cable connection status from the main servo board J8 to the adapter board J4-2. Confirm the cable connection status from the main servo board J2 to the adapter board J4-3.

	Check the cable connection from main servo board J9 to power board J3. Spindle
E110	motor start/stop position malfunction. Turn off power and restart. Check the cable connection from spindle motor to front panel ZD. Check the cable connection from main control board J5 to adapter board J1-3. Check the cable connection from main servo board J3 to main control board J3. Check the cable connection from main servo board J8 to adapter board J4-2. Check the cable connection from main servo board J2 to adapter board J4-3. Check the cable connection from main servo board J9 to power board J3. Spindle motor malfunction.
E111	Turn off power and restart. Check the cable connection from spindle motor to front panel ZD. Check the cable connection from main control board J5 to adapter board J1-3. Check the cable connection from main servo board J3 to main control board J3. Verify the cable connection from main servo board J8 to adapter board J4-2. Verify the cable connection from main servo board J2 to adapter board J4-3. Verify the cable connection from main servo board J9 to power board J3.

### 2.2.3 Fabric feeding malfunctions

Alarm Code	Cause and Solution: After
E200	power is on, the X-axis motor cannot find its origin. Turn off the power and restart. Check if the mechanical parts are stuck. Confirm the cable connection from the X-axis motor to the XD position on the front panel. Confirm the cable connection from the main control board J10 to the adapter board J1-2. Confirm the cable connection from the main control board J5 to the adapter board J1-3.
E201	The X-axis motor experienced a significant loss of synchronization during fabric feeding. Power off and restart. Verify the cable connection from the X-axis motor to position XD on the front panel. Verify the cable connection from main control board J10 to adapter board J1-2. Verify the cable connection from main control board J5 to adapter board J1-3. Verify
E210	the Y-axis motor encoder is securely installed. After powering on, the Y-axis motor cannot find its origin. Power off and restart. Check for any mechanical jamming. Verify the cable connection from the Y-axis motor to position YD on the front panel. Verify the cable connection from main control board J11 to adapter board J1-2. Verify the cable connection from main control board J5 to adapter board J1-3.
E211	The Y-axis motor experienced a significant loss of synchronization during fabric feeding. Power off and restart. Verify the cable connection from the X-axis motor to the YD position on the front panel. Verify the cable connection from the main control board J11 to the adapter board J1-2.

	<p>Confirm the cable connection status from the main control board J5 to the adapter board J1-3.</p> <p>Confirm that the Y-axis motor encoder is securely installed.</p>
--	--

## 2.2.4 Faults related to the presser foot

Alarm Code	Causes and solutions
E300	<p>After the power is turned on, the press foot motor cannot find the origin.</p> <p>Turn off the power and restart.</p> <p>Confirm the cable connection from the presser foot motor to the TD position on the front panel.</p> <p>Confirm the cable connection status between the main control board J12 and the adapter board J1-2.</p> <p>Confirm the cable connection status from the main control board J5 to the adapter board J1-3.</p> <p>Confirm that the encoder for the lifting foot motor is securely installed.</p>

## 2.2.5 Faults related to data editing

Alarm Code	Causes and solutions
E500	<p>Due to the magnification setting, the sewing data exceeded the sewing range.</p> <p>Set the magnification again.</p>
E501	<p>Sewing data beyond the sewing machine's possible sewing range was read.</p> <p>Confirm the flower pattern data.</p> <p>Confirm that the presser foot frame is suitable.</p>
E512	<p>Stop sewing the floral pattern halfway through (it wasn't finished).</p> <p>Turn off the power and restart.</p>

## 2.2.6 Equipment-related malfunctions

Alarm Code	Causes and solutions
E690	<p>The origin of the clamping line is incorrect.</p> <p>Turn off the power and remove any cotton dust from the inside of the needle plate.</p> <p>Check if any parts of the wire clamping device are damaged.</p> <p>Confirm the cable connection status from the clamp position detector to the JK position on the front panel.</p> <p>Confirm the cable connection status from the main control board J5 to the adapter board J1-3.</p> <p>Readjust the position of the origin of the clamp line.</p>
E691	<p>The clamping line was positioned incorrectly.</p> <p>Check if the amount of noodle residue is too long.</p> <p>Turn off the power and remove any cotton dust from the inside of the needle plate.</p> <p>Check if any parts of the wire clamping device are damaged.</p> <p>Confirm the cable connection status from the clamp position detector to the JK position on the front panel.</p> <p>Confirm the cable connection status from the main control board J5 to the adapter board J1-3.</p> <p>Readjust the position of the clamp line retreat.</p>

## 2.2.7 Other faults

Alarm Code	Causes and solutions
E452	<p>The head unit identifier is not properly connected.</p> <p>Confirm the cable connection from the head unit identifier to the JK position on the front panel.</p> <p>Confirm the cable connection status from the main control board J4 to the adapter board J8-3.</p>

## 2.3 No alarms or abnormal conditions

### 2.3.1 Power switch malfunction

Phenomenon description	processing method
<p>After turning on the power, the motor did not...</p> <p>Locked;</p> <p>The machine did not perform the origin-finding action;</p> <p>The keyboard is not displaying anything;</p>	<p>Check the cable connections inside the power switch box.</p> <p>Check the status of the power board fuses.</p> <p>Confirm that indicator lights D2 and D3 on the main control board remain active after the power switch is turned on.</p> <p>Bright.</p> <p>Confirm that the indicator lights LD1 and LD3 on the main servo board are active after the power switch is turned on.</p> <p>Are indicator lights LD2 and LE03 constantly on after the power switch is turned on?</p> <p>Slow flashing.</p> <p>Confirm the cable connection status from power board J1 to the power socket on the rear panel.</p> <p>Confirm the cable connection status from power board J3 to main servo board J9.</p> <p>Confirm the cable connection status from power board J1 to main control board J1.</p>

### 2.3.2 Electromagnet Failure

Phenomenon description	processing method
<p>The electromagnet does not attract;</p> <p>The electromagnet is attracted, but until</p> <p>Loosen it only when the next sewing begins;</p> <p>The electromagnet is engaged and will not release.</p>	<p>Confirm that the electromagnet is connected to the front panel SC (loose wire electromagnet) or JC (cut wire electromagnet).</p> <p>The cable connection status at the location of the electromagnet.</p> <p>Confirm the cable connection status from J8 on the main control board to J5-4 on the adapter board.</p> <p>condition.</p> <p>Confirm that the electromagnet assembly is installed correctly.</p> <p>Check if the electromagnet is broken.</p>

### 2.3.3 Keyboard malfunction

The keyboard display	processing method
<p>is malfunctioning.</p> <p>The keyboard displays nothing.</p> <p>The keyboard keys are not working.</p>	<p>Check the cable connection from the keyboard to the JP position on the front panel.</p> <p>Confirm the cable connection status from J5 on the main control board to J1-3 on the adapter board.</p> <p>condition.</p>

2.3.4 The machine is in an abnormal state after startup.

Phenomenon description	The troubleshooting
<p>The power light is not on, and the sewing machine cannot start; the sewing machine is malfunctioning.</p>	<p>steps are as follows: First, confirm the cable connection from power board J1 to the power plug on the rear panel. Second, confirm the cable connection from power board J2 to the transformer. Third, confirm the cable connection from power board J3 to the spindle servo board J9. Fourth, confirm the cable connection from power board J4 to the main control board J2. Fifth, confirm the cable connection from power board J6 to the main control board J1.</p>

2.3.5 After sewing is completed, there is still some extra movement on the presser foot frame.

The phenomena	processing method
<p>described are as follows: After one sewing cycle, the presser foot frame moves forward or backward excessively; After one sewing cycle, the presser foot frame shakes continuously</p>	<p>Confirm that the installation clearance of the Y-axis fabric feeding mechanism meets the standard. Confirm that the Y-axis motor encoder is securely installed.</p>
<p>back and forth; After one sewing cycle, the presser foot frame moves left or right excessively; After one sewing cycle, the presser foot frame shakes continuously left and right.</p>	<p>Confirm that the installation clearance of the X-axis fabric feeding mechanism meets the standard. Confirm that the X-axis motor encoder is securely installed.</p>